

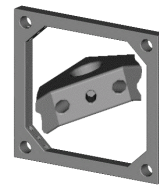

AFILTRATION.COM, INC.

Manufacturing Plastics Mold Specialist Filter Elements Division.
 2001 Zapata Street * Freeport, Texas 77541-3321
 TEL: (979) 239-1700 * FAX: (979) 239-1727
 www.afiltration.com * E-mail: sales@afiltration.com



Flush Plate & Frame Filter Element

FPRFPF0178-D

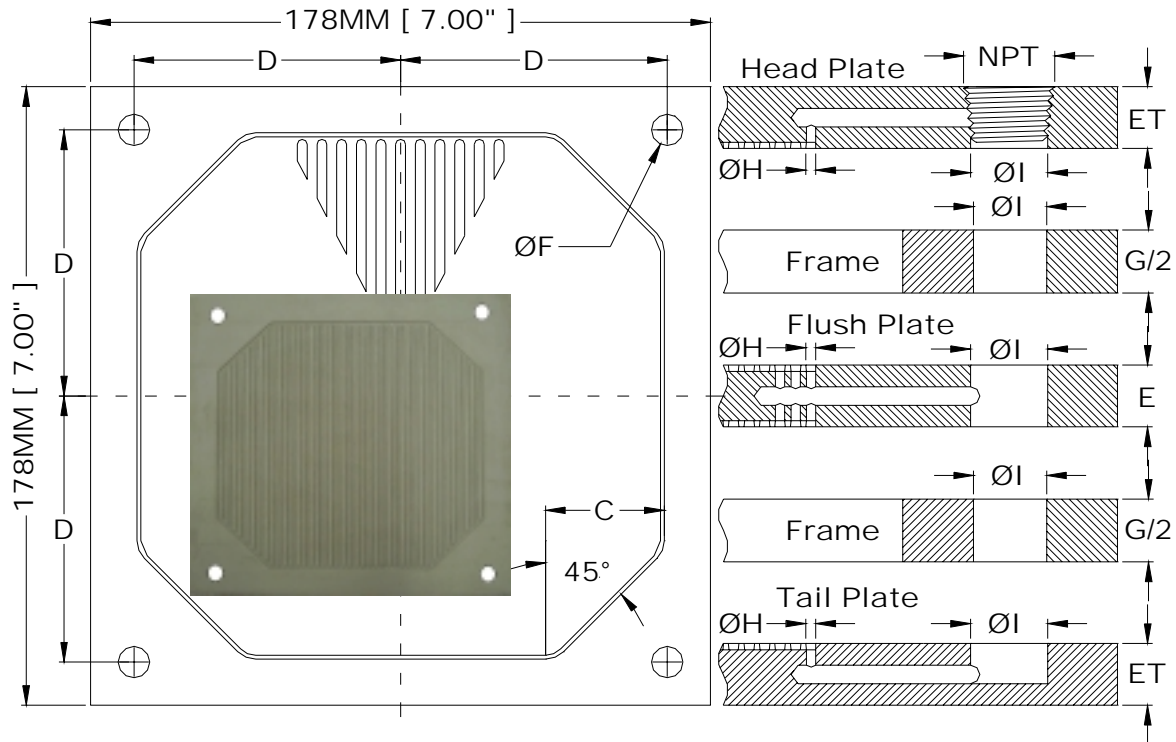

Polypropylene machine to Flush Plate & Frame filter element with ribs filtration area, Ribs height 4 mm, Approx. 70 % open filtration area, Operating pressure 16 bar, Various materials: please see type key Main Dimensions acc.

Aluminum 6061-T6 machine to Flush Plate & Frame filter element with ribs filtration area, Ribs height 4 mm, Approx. 70 % open filtration area, Operating pressure 16 bar, Various materials: please see type key Main Dimensions acc.

Stainless Steel 304 machine to Flush Plate & Frame filter element with ribs filtration area, Ribs height 4 mm, Approx. 70 % open filtration area, Operating pressure 16 bar, Various materials: please see type key Main Dimensions acc.

V= Volume Area (Cu.Ft)

M= Plate Weight

A= Filtration Area (SQ.Ft)

Dimensions MM

Filter Cake	Support Bossed	Corner Pad	Discharge Holes	Thickness		Feed Hole	Head Plate	Down Porting	Discharge Dia	Plate Weight	Filter Area	Volume Area
G/2	B	C	D	E	ET	F	NPT	H	I	M	A	V
mm	mm	mm	mm	mm	mm	mm	In	mm	mm	Kg	Ft ²	Ft ³
25		40.0	69.85	25	25	12.7	0.50	6.35	12.70	0.8	0.355	0.120
32		40.0	69.85	25	25	12.7	0.50	6.35	12.70	0.8	0.444	0.150
38		40.0	69.85	25	25	12.7	0.50	6.35	12.70	0.8	0.533	0.180
50		40.0	69.85	25	25	12.7	0.50	6.35	12.70	0.8	0.710	0.240

Dimensions Inch

Filter Cake	Support Bossed	Corner Pad	Discharge Holes	Thickness		Feed Hole	Head Plate	Down Porting	Discharge Dia	Plate Weight	Filter Area	Volume Area
G/2	B	C	D	E	ET	F	NPT	H	I	M	A	V
Inch	Inch	Inch	Inch	Inch	Inch	Inch	Inch	Inch	Inch	lbs	Ft ²	Ft ³
1"		1.575	2.750	1.000	1.000	0.500	0.50	0.250	0.500	1.7	0.355	0.120
1 1/4"		1.575	2.750	1.000	1.000	0.500	0.50	0.250	0.500	1.7	0.444	0.150
1 1/2"		1.575	2.750	1.000	1.000	0.500	0.50	0.250	0.500	1.7	0.533	0.180
2"		1.575	2.750	1.000	1.000	0.500	0.50	0.250	0.500	1.7	0.710	0.240