

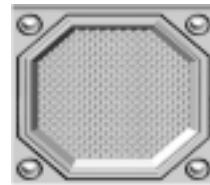

# AFILTRATION.COM, INC.

Manufacturing Plastics Mold Specialist Filter Elements Division.  
 2001 Zapata Street \* Freeport, Texas 77541-3321  
 TEL: (979) 239-1700 \* FAX: (979) 239-1727  
 www.afiltration.com \* E-mail: sales@afiltration.com



## (CGR) Cloth & Gasket Chamber Plate Filter Element

K0250-CGR-16-S0

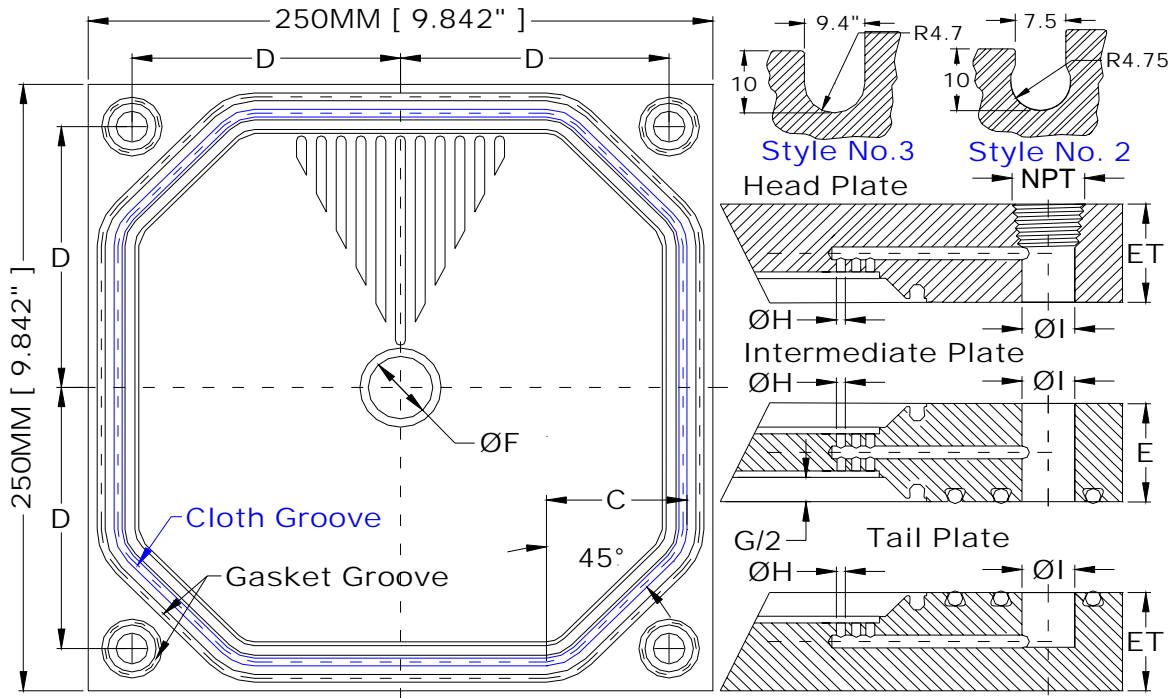

Polypropylene molded chamber filter element with piped filtration area, Pip height 4 mm, pip diameter 8 mm, Approx. 68 % open filtration area, Operating pressure 16 bar, Various materials: please see type key Main Dimensions acc.

Aluminum 6061-T6 machine to chamber filter element with ribs filtration area, Ribs height 4 mm, Approx. 68 % open filtration area, Operating pressure 16 bar, Various materials: please see type key Main Dimensions acc.

V= Volume Area (Cu.Ft)                      M= Plate Weight                      A= Filtration Area (SQ.Ft)

### Dimensions MM

Filter Cake	Support Bossed	Corner Pad	Discharge Holes	Thickness		Feed Hole	Head Plate	Down Porting	Discharge Dia	Plate Weight	Filter Area	Volume Area
G/2	B	C	D	E	ET	F	NPT	H	I	M	A	V
mm	mm	mm	mm	mm	mm	mm	In	mm	mm	Kg	Ft <sup>2</sup>	Ft <sup>3</sup>
15		87.0	95.25	35	35	38.1	0.50	6.35	19.05	2.0	0.495	0.011
20		82.0	95.25	40	40	38.1	0.50	6.35	19.05	2.3	0.527	0.015
25		77.0	95.25	45	45	38.1	0.50	6.35	19.05	2.5	0.570	0.019
30		72.0	95.25	50	50	38.1	0.50	6.35	19.05	2.7	0.603	0.023
32		71.0	95.25	52	52	38.1	0.50	6.35	19.05	3.2	0.603	0.025
38		65.0	95.25	57	57	38.1	0.50	6.35	19.05	3.4	0.635	0.030

### Dimensions Inch

Filter Cake	Support Bossed	Corner Pad	Discharge Holes	Thickness		Feed Hole	Head Plate	Down Porting	Discharge Dia	Plate Weight	Filter Area	Volume Area
G/2	B	C	D	E	ET	F	NPT	H	I	M	A	V
Inch	Inch	Inch	Inch	Inch	Inch	Inch	Inch	Inch	Inch	Lbs	Ft <sup>2</sup>	Ft <sup>3</sup>
5/8"		3.425	3.750	1.378	1.378	1.50	0.50	0.250	0.75	4.5	0.495	0.011
3/4"		3.228	3.750	1.575	1.575	1.50	0.50	0.250	0.75	5.0	0.527	0.015
1"		3.031	3.750	1.772	1.772	1.50	0.50	0.250	0.75	5.5	0.570	0.019
1 3/16"		2.835	3.750	1.969	1.969	1.50	0.50	0.250	0.75	6.0	0.603	0.023
1 1/4"		2.795	3.750	2.047	2.047	1.50	0.50	0.250	0.75	7.0	0.603	0.025
1 1/2"		2.559	3.750	2.244	2.244	1.50	0.50	0.250	0.75	7.5	0.635	0.030