

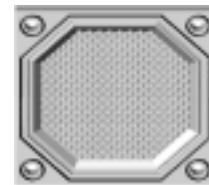

# AFILTRATION.COM, INC.

Manufacturing Plastics Mold Specialist Filter Elements Division.  
 2001 Zapata Street \* Freeport, Texas 77541-3321  
 TEL: (979) 239-1700 \* FAX: (979) 239-1727  
 www.afiltration.com \* E-mail: sales@afiltration.com



## (CGR) Cloth & Gasket Chamber Plate Filter Element

K1200-CGR-16-S4

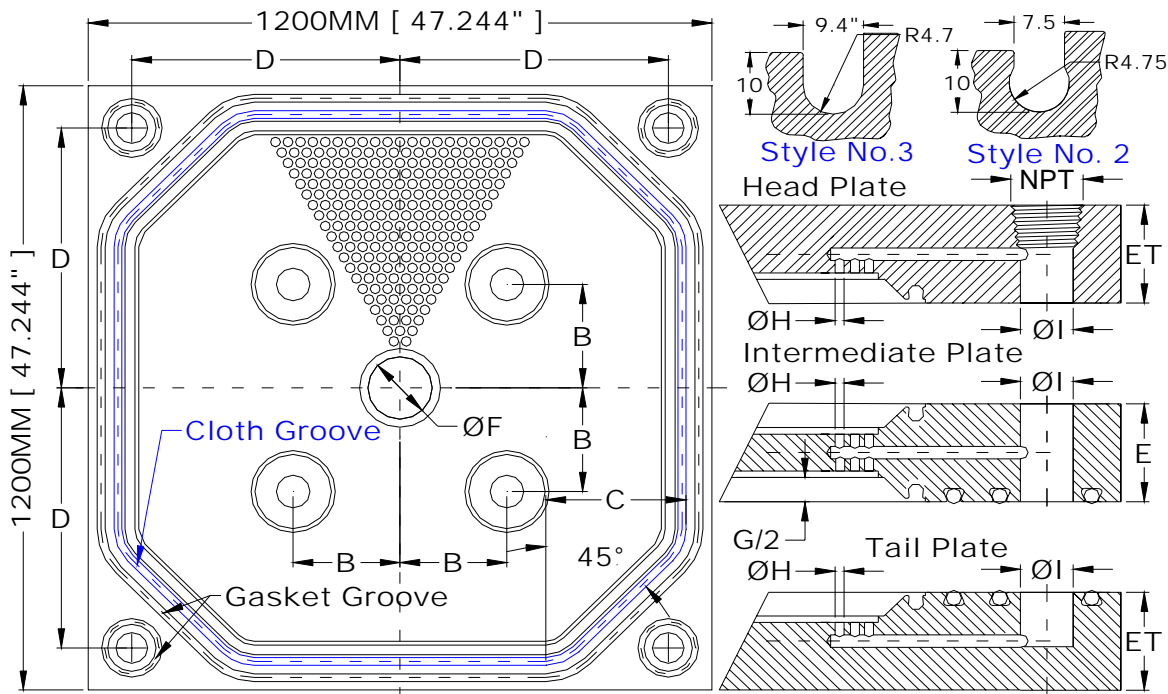

Polypropylene molded chamber filter element with piped filtration area, Pip height 4 mm, pip diameter 8 mm, Approx. 68 % open filtration area, Operating pressure 16 bar, Various materials: please see type key Main Dimensions acc.

Aluminum 6061-T6 machine to chamber filter element with ribs filtration area, Ribs height 4 mm, Approx. 68 % open filtration area, Operating pressure 16 bar, Various materials: please see type key Main Dimensions acc.

V= Volume Area (Cu.Ft)                      M= Plate Weight                      A= Filtration Area (SQ.Ft)

### Dimensions MM

Filter Cake	Support Bossed	Corner Pad	Discharge Holes	Thickness Plate		Feed Hole	Head Plate	Down Porting	Discharge Dia	Plate Weight	Filter Area	Volume Area
G/2	B	C	D	E	ET	F	NPT	H	I	M	A	V
mm	mm	mm	mm	mm	mm	mm	In	mm	mm	Kg	Ft <sup>2</sup>	Ft <sup>3</sup>
15	175.0	195.0	520.7-533.4	45	54	76.2-152.4	1.50-3.00	8.0	51-76	44.9	24.413	0.588
20	175.0	190.0	520.7-533.4	50	57	76.2-152.4	1.50-3.00	8.0	51-76	46.3	24.499	0.782
25	175.0	185.0	520.7-533.4	55	59	76.2-152.4	1.50-3.00	8.0	51-76	48.1	24.574	0.975
30	175.0	180.0	520.7-533.4	60	61	76.2-152.4	1.50-3.00	8.0	51-76	49.4	24.649	1.167
32	175.0	178.0	520.7-533.4	62	62	76.2-152.4	1.50-3.00	8.0	51-76	49.9	24.682	1.243
38	175.0	172.0	520.7-533.4	68	65	76.2-152.4	1.50-3.00	8.0	51-76	51.7	24.778	1.470

### Dimensions Inch

Filter Cake	Support Bossed	Corner Pad	Discharge Holes	Thickness Plate		Feed Hole	Head Plate	Down Porting	Discharge Dia	Plate Weight	Filter Area	Volume Area
G/2	B	C	D	E	ET	F	NPT	H	I	M	A	V
Inch	Inch	Inch	Inch	Inch	Inch	Inch	Inch	Inch	Inch	Lbs	Ft <sup>2</sup>	Ft <sup>3</sup>
5/8"	6.890	7.677	20.50-21.00	1.772	2.126	3.00-6.00	1.50-3.00	0.315	1.50-3.00	99.0	24.413	0.588
3/4"	6.890	7.480	20.50-21.00	1.969	2.244	3.00-6.00	1.50-3.00	0.315	1.50-3.00	102.0	24.499	0.782
1"	6.890	7.283	20.50-21.00	2.165	2.323	3.00-6.00	1.50-3.00	0.315	1.50-3.00	106.0	24.574	0.975
1 3/16"	6.890	7.087	20.50-21.00	2.362	2.402	3.00-6.00	1.50-3.00	0.315	1.50-3.00	109.0	24.649	1.167
1 1/4"	6.890	7.008	20.50-21.00	2.441	2.441	3.00-6.00	1.50-3.00	0.315	1.50-3.00	110.0	24.682	1.243
1 1/2"	6.890	6.772	20.50-21.00	2.677	2.559	3.00-6.00	1.50-3.00	0.315	1.50-3.00	114.0	24.778	1.470